



Infrared Conveyor Ovens

Job _____ Item# _____

Conveyor Oven Gemini Model DZ33II with Menu Select®



Model DZ33II
Shown on Optional Base

to 240.0 minutes. Each deck has its own power circuit breaker, manual "ON/OFF" switch, conveyor reversing keyswitch and a mode changing "PROGRAM/OPERATE" keyswitch.

MenuSelect®

The patented MenuSelect® feature allows the operator to preset up to six different time and temperature combinations into the control that can be recalled by pressing the appropriate preset key, then the computer automatically adjusts time (belt speed) and temperatures. A ready message is displayed when the desired temperatures are reached.

Agency Data

The Gemini DZ33II is ETL Safety and Sanitation Certified; and compliant with CE requirements.

Warranty

Warranted for one year covering parts and labor under the "No Quibble" warranty. USA only.

Electrical Ordering Information

- 208VAC, 1-Phase or 3-Phase
- 240VAC, 1-Phase or 3-Phase
- 380VAC, 3-Phase
- 415VAC, 3-Phase

*Consult the electrical data on the rear side of this specification sheet for connected kW and amperage loading representing your local utility.

Accessories At Extra Cost

- ACHST33SH - Base Assembly - Short, 17"
- ACHST33TL - Base Assembly - Tall, 32-1/2"
- ACHSHDZ33 - Stainless Steel Undershelf
- ACSBDZ - Gemini Stacking Bracket
- ACHCDZ - Set Of Two Heat Curtains
- ACET Exit Tray - 15-1/2"
- ACETL Exit Tray - 22-1/2"
- ACSKDZ3355 Stacking Bracket - DZ33II on a DZ55II

Application

CTX conveyor ovens are designed to cook, bake or broil in high volume with consistent quality results.

General Information

Heavy-duty, electric, conveyor ovens are designed for mounting on a modular base. Oven consists of 2 complete and separated cooking chambers (decks), equipped with 18" wide stainless steel chain link belt. Overall dimensions are 59"W by 36"D by 28"H. Oven chambers are 31"W by 22 1/2"D by 51 1/2"H. Ovens may be stacked two high on a short base.

Construction

The outer body is constructed with 18-gauge stainless steel. Oven chambers are constructed of welded and reinforced 16-gauge aluminized steel. Infrared heat emitters are enclosed in high-strength thermal conductive steel plates that form the upper and lower housing of the oven chambers.

Insulation

The oven is fully insulated on all four sides and top with high temperature insulation.

Electrical

Ovens can be ordered for 208VAC, 240VAC, 380VAC or 415 VAC

electrical utilities. The total power input on 208 and 240VAC is 19.0 kW; 380VAC is 16.8 kW. The average operating power input is 6.3 kW for 208 and 240VAC. The ovens can be wired for either 1-phase or 3-phase electrical connection on 208 and 240VAC. Electrical cord knock-outs are provided on the lower left-hand front side panel of the oven. An access panel on the lower, left front corner of the oven available for making electrical connections.

Heating

Heating is accomplished with eight (8) far-infrared emitters. four infrared emitters are located above and below each oven deck. When food product is placed on the conveyor belt, it cooks as it passes between the top and bottom emitters. Oven operates coolly, quietly and requires minimal ventilation.

Controls

Each deck is individually controlled by a separate microprocessor, which includes a time/date clock for automatic turn "ON" and turn "OFF", an energy-conserving standby mode and a self-cleaning cycle. Both decks also feature left and right heat zones with directional heat capability from above and below the conveyor. The temperature may be set from 200° to 900°F, and the cooking time range may be set from 1.5



A MIDDLEBY COMPANY

1400 Toastmaster Drive
Elgin, Illinois 60120 USA
(847) 741-3300 Fax: (847) 741-0015
www.middleby-marshall.com
www.ctxautomation.com



Conveyor Oven Gemini Model DZ33II with Menu Select®

We reserve the right to change specifications and product design without notice. Such revisions do not entitle the buyer to corresponding changes, improvements, additions or replacements for previously purchased equipment.

NOTE: ALL FIGURES IN PARENTHESES ARE IN MILLIMETERS.

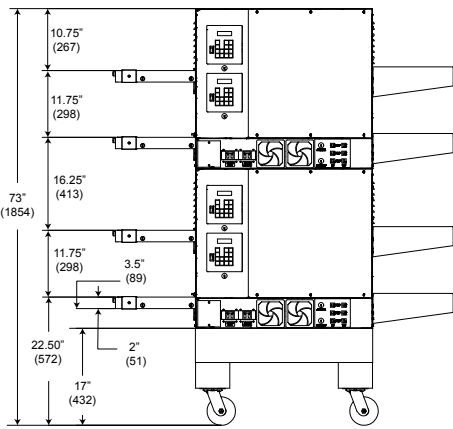
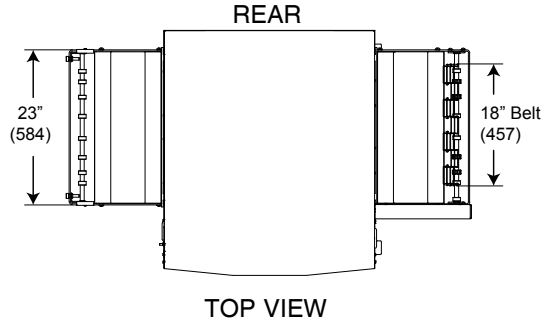

SIDE VIEW
(TWO MODULES WITH BASE)

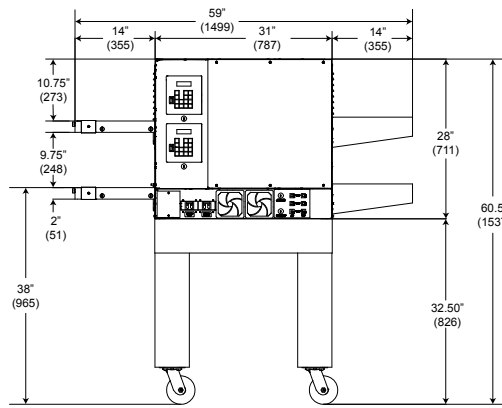

SIDE VIEW
(ONE MODULE WITH BASE)

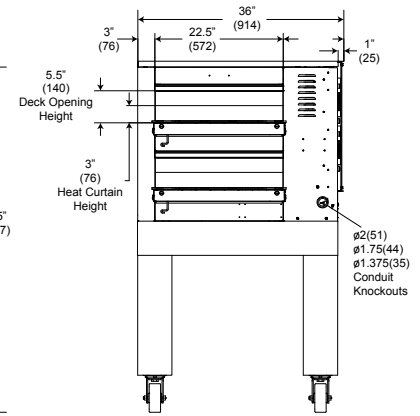

END VIEW

ELECTRICAL DATA - One Power Supply

| MODEL NO | AC VOLTS | PHASE | Hz | CONNECTED kW | AVG OPERATING kW | CONNECTED LOAD (AMPS) | | | |
|-----------------------|----------|-------|-------|--------------|------------------|-----------------------|------|------|------|
| | | | | | | L1 | L2 | L3 | N |
| DZ33II | 208 | 1 | 50/60 | 19.0 | 6.3 | 91.5 | 91.5 | -- | -- |
| DZ33II | 208 | 3 | 50/60 | 19.0 | 6.3 | 60.5 | 60.5 | 39.6 | -- |
| DZ33II | 240 | 1 | 50/60 | 20.0 | 6.3 | 83.3 | 83.3 | -- | -- |
| DZ33II | 240 | 3 | 50/60 | 20.0 | 6.3 | 55.1 | 55.1 | 36.1 | -- |
| DZ33II (CE Listed) | 380 | 3 | 50/60 | 16.8 | 6.3 | 28.6 | 19.1 | 28.6 | 9.5 |
| DZ33II | 415 | 3 | 50 | 20.0 | 6.3 | 31.3 | 20.8 | 31.3 | 10.5 |

| NET WT OVEN | SHIPPING WEIGHTS | | | OVEN - SHIPPING DIMENSIONS | | |
|-------------------|-------------------|------------------|------------------|----------------------------|---------------|---------------|
| | Oven | 17" Base | 33" Base | Length | Width | Height |
| 510 lbs 232 kg | 645 lbs 293 kg | 115 lbs 52 kg | 130 lbs 59 kg | 90" (2286) | 43" (1092) | 44" (1118) |

